Masters Theses

Student Theses and Dissertations

1972

High speed magnetically supported vehicles for reducing transportation's degradations of the environment

Pravinchandra Shukla

Follow this and additional works at: https://scholarsmine.mst.edu/masters_theses

 Part of the [Civil Engineering Commons](#), and the [Environmental Engineering Commons](#)

Department:

Recommended Citation

Shukla, Pravinchandra, "High speed magnetically supported vehicles for reducing transportation's degradations of the environment" (1972). *Masters Theses*. 3526.

https://scholarsmine.mst.edu/masters_theses/3526

This thesis is brought to you by Scholars' Mine, a service of the Missouri S&T Library and Learning Resources. This work is protected by U. S. Copyright Law. Unauthorized use including reproduction for redistribution requires the permission of the copyright holder. For more information, please contact scholarsmine@mst.edu.

HIGH SPEED MAGNETICALLY SUPPORTED VEHICLES FOR REDUCING
TRANSPORTATION'S DEGRADATIONS OF THE ENVIRONMENT

by

PRAVINCHANDRA SHUKLA, 1946-

A THESIS

Presented to the Faculty of the Graduate School of the

UNIVERSITY OF MISSOURI - ROLLA

In Partial Fulfillment of the Requirements for the Degree

MASTER OF SCIENCE IN ENVIRONMENTAL AND PLANNING ENGINEERING

1972

Approved by

Lawrence K. Sieck (Advisor) James L. Joany

Xavier JR Anula

ABSTRACT

The development of new techniques for higher speed transportation is desirable to satisfy the environmental, conservation, and economic requirements of society. Some of the important factors are presented for developing magnetically supported vehicles. A new method for improving the ratio of lift force to drag force is suggested and discussed. An application of the new technique to vehicles that would ride on a carpet of magnetism and would operate with less waste of energy is suggested.

ACKNOWLEDGEMENTS

The professional advice and leadership of my advisor, Dr. Lawrence K. Sieck, is gratefully acknowledged and sincerely appreciated. The valuable advice and constructive criticism of Dr. Josey, James L., and Dr. Avula, Xavier J., is sincerely appreciated. Thanks go also to Mrs. Eunice French for typing this manuscript.

I express my deep feelings of love and respect toward my wife whose help and inspiration made my education possible.

TABLE OF CONTENTS

	PAGE
ABSTRACT	ii
ACKNOWLEDGEMENTS	iii
LIST OF FIGURES.	vi
LIST OF TABLES	vii
I. INTRODUCTION	1
A. Importance to Society.	2
B. Technical View	5
C. Objectives	8
II. REVIEW OF LITERATURE	9
A. History.	9
B. Superconductivity.	9
C. Applications	12
D. Development of Technology.	14
1. Lift to Drag Force Ratio	14
2. Width of the Roadbed	19
3. Track of the Vehicles.	22
4. Linear Electric Motor.	22
5. Underground Power Distribution	23
6. Conservation of Energy	24
III. DISCUSSION	29
A. The Proposed System.	29
1. The Flying Train	29
2. PRT System	30
B. Environmental and Economic Aspects	30
1. Noise Pollution Control.	30
2. Air Pollution Control.	32

TABLE OF CONTENTS (cont'd)	PAGE
3. Land Use Efficiency	33
4. Fare Charge Per Passenger and Capacity.	37
5. Economics and Cost Trends	39
6. Comparison With Present System. . .	40
7. Government Attitude	41
IV. CONCLUSIONS	42
A. Summary	42
B. Technical Recommendations	43
BIBLIOGRAPHY	44
VITA	46

LIST OF FIGURES

FIGURE NO.		PAGE
1	Magnetically supported train	6
2	Personal rapid transit	7
3	Modified sketch for experiment	16

LIST OF TABLES

TABLE NO.		PAGE
I	Relationship between the ratio of lift to drag force and ratio of height of magnet and width of the roadbed.	21
II	Comparison of underground to overhead power transmission	25
III	U. S. Energy budget in QBTUs (Quadrillion BTUs) for 1968	26
IV	Energy for transportation in QBTUs (Quadrillion BTUs)	28
V	Standards for allowable emission of gases. .	34

I. INTRODUCTION

Everybody wants a better environment and an improved quality of life. A change for the betterment and improvement of life's quality gives pleasure to human beings. Engineering research and new technology in traffic and transportation systems promise significant environmental improvement, as well as other important benefits for society. The magnetically supported vehicles would be beneficial to society for several reasons, such as: energy conservation, a better ability to cope with population increases, a reduction in numbers of automobiles and reduced parking problems. The cost of the system to the individual and the nation would be less than that of the present system of automobile transport.

The Governor of New York State, Nelson A. Rockefeller's letter (13) indicates how better transportation is important to society.

"Though New York has long been famed for its economic growth and prosperity, it has never known the equal of the period it is now entering.

Accompanying this unprecedented expansion is the need for more and better transportation facilities. In less than eight more years, over a million additional cars will take to our highways. Last year's road building and improvement projects, costing about a half-billion dollars, set a pace that must and will soon be surpassed.

The challenge and the opportunity for the engineering profession in such a vital environment is unsurpassed. I, for one, count it a

privilege to serve New York is these stimulating and richly rewarding times. I welcome your interest in the future of transportation, and I invite you to grow with the growing Empire State."

A. Importance to Society

The migratory nature of the people and their enjoyment of a better and higher quality of life would be enhanced by the increased speed and efficiency of proposed new traffic and transportation systems. Among the present problems of society are automobile traffic congestion and loss of environmental quality. Both problems are caused in part by excessive and almost exclusive dependence upon automobile technology for transportation. Also the automobile requires excessive amounts of fuel and thus requires the nation to aggravate its foreign payments deficit to pay for petroleum energy imports. Day by day, population and numbers of vehicles increase, petroleum shortages increase, and hence traffic and pollution problems and payment problems become more difficult to solve.

Historically, traffic problems have always arisen from the systems of transportation in use. Everybody wants to save time. Time is related to money, and time usage in turn is related to the success of any individual

in accomplishing his daily tasks. Traffic engineers are at present seeking higher speed transportation systems which are better solutions for society's environmental requirements; as well as solving pollution problems, traffic congestion, parking difficulties, energy conservation and economic and financial constraints.

The number of automobiles increases faster than the population. Fuel imports for the automobile are increasing at a far greater rate than either the vehicle or population trends. Recent reports indicate that over 40% of petroleum consumption in the United States this year had to be imported. Also, the traffic control problems of automobile transportation are increasing in complexity and appear in many cases to be unsolvable.

The new technique of magnetically supported vehicles hopefully will solve some of the automobile-related problems, such as: too high a speed for average drivers, traffic congestion, parking, traffic accidents, pollution, economic costs, etc. The magnetically supported vehicle can solve the most important problem of energy conservation and help prevent the future fuel shortages that are predicted. For example, Mr. John G. McLean, Continental Oil Corporation Chairman reports that the United States now expends 4 billion dollars per year for petroleum imports. By 1980 the petroleum imports are expected to be 30 billion per year. From such predictions it is reasonable to assume that the running cost of

automobiles will soon be very much higher. Extremely low cost and abundant petroleum energy has made automobile transportation available for all income levels in the past. But in the future the people from the middle and lower income society will not be able to keep operating an automobile for their own private transportation.

In consideration of railroad transportation the Deputy Administrator of the Federal Railroad Administration, Henri F. Rush, Jr., said in an address to the American Railway Engineering Association (1):

"We estimate an average of 62,000 new and rebuilt freight cars will be needed annually during the period 1971 to 1980 for replacement purposes. In addition another 43,000 cars per year will be needed through 1974 to bring the national fleet up to an appropriate level. Through 1980 this comes to a total of approximately 750,000 cars at a cost of 11.1 billion."

The above detail suggests the equipment needs of the existing rail transport technology. It also would indicate that a study of the new techniques of magnetic suspension is timely. Such a system promises to be economic and speedy as well. Existing railroad technology is already very efficient in fuel consumption. It takes about eight gallons of fuel for auto and truck transportation when only one gallon is needed to produce the same amount of transportation with railroad technology (3).

High speed transportation will be needed in new town and new urbanization programs to provide more expeditious and congestion-free connections between residential and industrial areas, as well as linking the households to commercial and recreational areas.

The magnetic suspension vehicles such as the flying train for mass transit as shown in Figure 1 and PRT (personal rapid transit) system as shown in Figure 2 offer solution that would be useful to all of us. If we consider all the aspects of the present situation, society is at crossroads and there is a great need for developing new techniques of transportation.

B. Technical View

The PRT system probably can be designed for speeds greater than 80 miles per hour and the flying train can be designed for perhaps 300 miles per hour. Research reports indicate that magnetically supported vehicles are safe and suitable for high speed transportation. In this system a magnetic field provides support for the vehicles. The suggested technique has a conducting platform which is made by fixed conducting plates on the roadbed. There are conducting coils in the vehicles carrying current which induces currents in the roadbed and which in turn

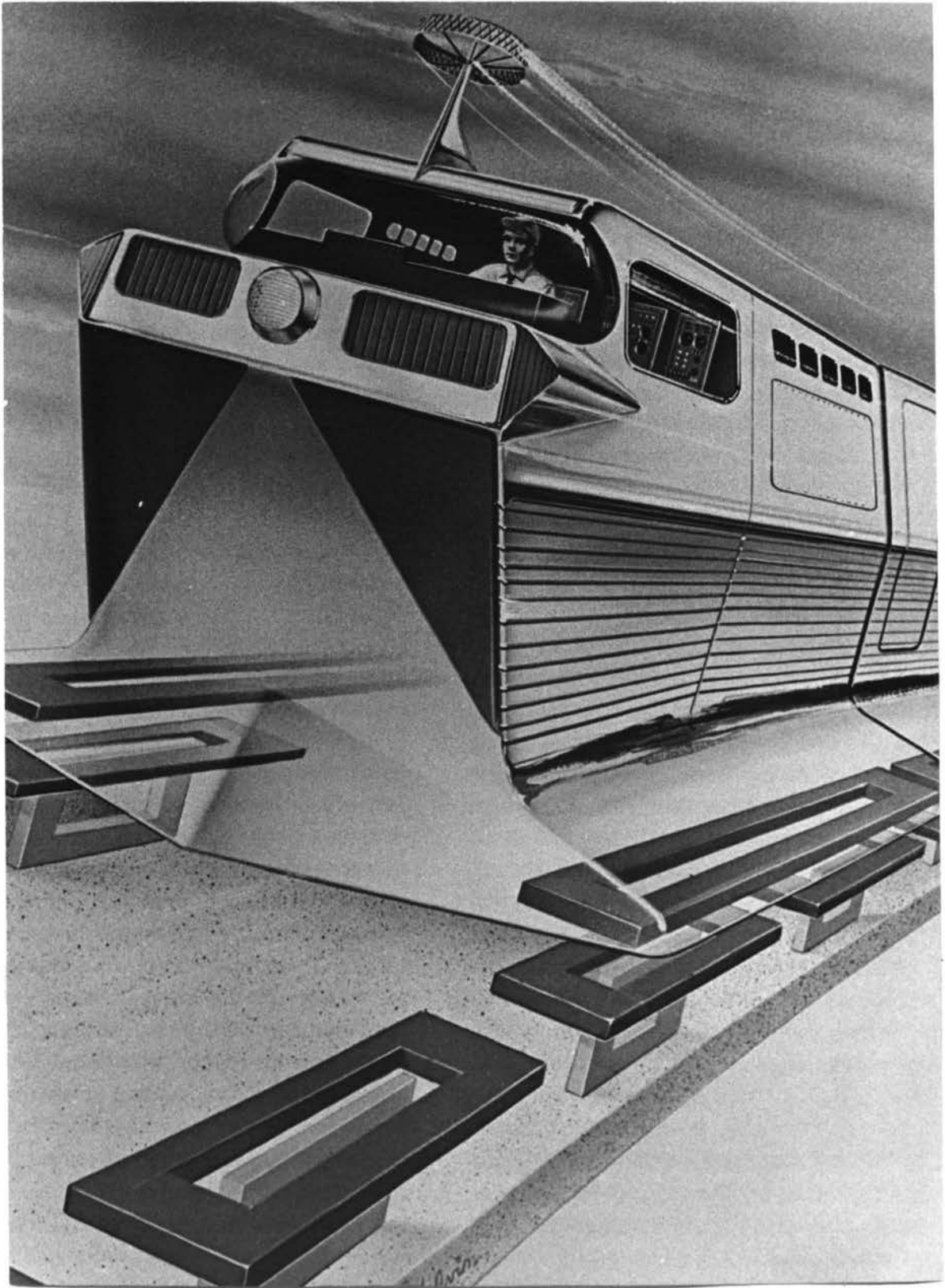

Figure 1 (7)-Magnetically supported train

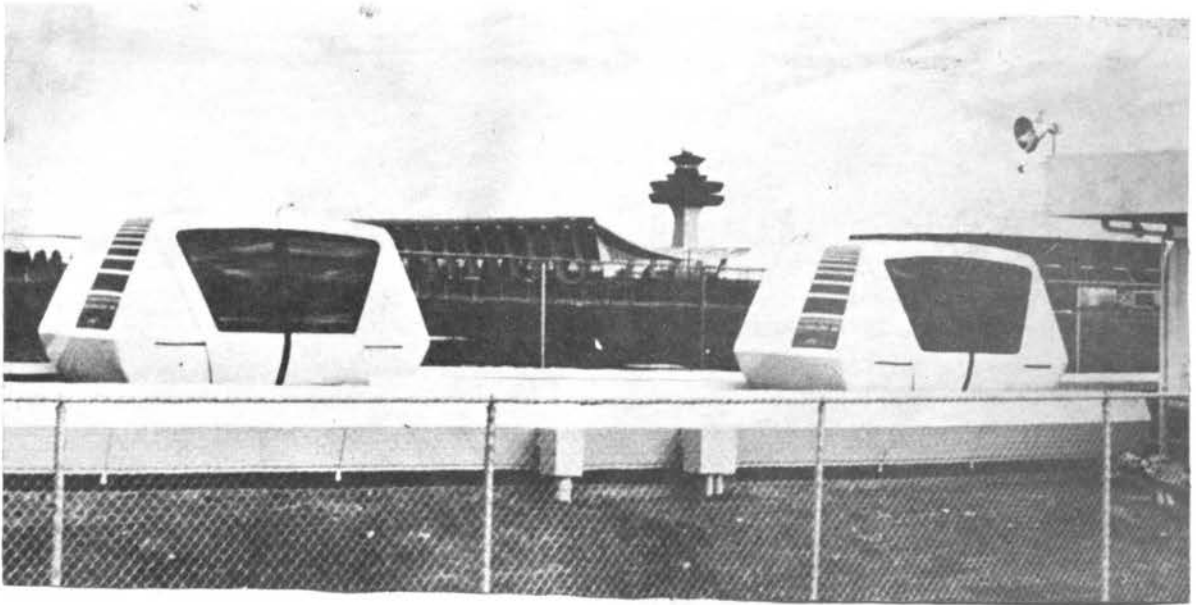

Figure 2 (15)-Personal rapid transit

develop an opposite magnetic force that suspends the vehicle.

First we can consider a simple case with a simple model which can lead us to solutions for actual problems. Conductor losses can be removed by using the properties of superconductivity.

C. Objectives

The objective of the study is to examine the environmental, transportation, conservation, and other benefits to society to be expected by use of magnetically suspended vehicles for high speed transportation. The study also evaluates some possible capacity and cost estimates. The question to be examined is how researchers proceeded in planning for the roadbed and the geometrical arrangement of the current carrying coil on the vehicles. A second objective is to estimate how the new technique protects our environment and helps to solve some of our present difficulties. The system must be as acceptable as possible to help society solve some of the transportation and environmental problems.

II. REVIEW OF LITERATURE

A. History

In the early 1900's there were a number of applications for cold magnets. A french scientist proposed an application of chilled magnets for a railway train which would ride on a carpet of magnetism. But due to World War I the idea was dropped.

Now-a-days many people are working in the field of superconductivity. Engineers are trying to use the magnetic field for many purposes.

B. Superconductivity

A free flow of electrons without resistance is the master key in the world of electrical science. We can get the most efficient electron flow system in the field of magnetism by using superconducting magnets or coils. Superconducting material results in optimum performance without the loss of energy associated with resistances at normal temperatures. An electric current never dies in the superconducting conductor.

A report edited by Lee Edson in Nature/Science Annual (7, p. 144) explained that Onnes a Dutch professor obtained the superconducting property of a metal when the

metal is at a low temperature:

"In 1911 he (Onnes) placed some mercury in a supercold bath of liquid helium and then connected the metal to a battery. As he lowered the temperature of the helium he expected that current would, in the normal way, travel through the mercury easily, with little resistance. To his utter amazement, his instruments showed that at a certain temperature resistance disappeared and the current retained its original strength. Apparently, an electric current could pass through the supercooled mercury without losing any of its energy on the way - something that the best electrical conductor previously known could not do . . . Onnes immediately realized that if a metal had no resistance, electricity could zip through a circuit without ever dying out. Showing a flair for the dramatic, he used a battery to start current in a ring of lead wire bathed in liquid helium; he then removed the battery, to transported the lead ring from Holland to England in a special flask and demonstrated to the fascinated Royal Society that the current was still flowing with undiminished strength. Onnes explained that the point at which mercury lost its resistance is at -452.2 degree F is called 'Transition Temperature'."

The demonstration proved that, in a supercooled metal, the current never dies even though there is no supply of power. Onnes realized that a helium cooled electromagnet would require a far lesser amount of power. Onnes worked a great deal on magnets and superconductivity. He concluded that a superconducting magnet would have a considerable advantage over conventional electromagnets because the current would keep going without additional power. Lee Edson (7, p. 145) continued his discussion of Onnes' research:

"Unfortunately he discovered that superconductivity in a magnet was its own enemy. When superconducting wire was used in a coil to create a magnetic field of any appreciable strength the superconductivity mysteriously disappeared and the wire reverted to a normal resistance regardless of the super critical low temperature. Onnes had no idea why magnetism turned out to be so antagonistic to superconductivity. The mystery spurred other scientists to explore the relationship. Nothing major occurred, however, until 1933, when the German investigators, Walter Meissner and R. Ochsenfeld, discovered another peculiarity between the poles of a magnet and lowered the temperature of the metal until it reached its superconducting transition point. As expected an induced magnetic field was present in the metal throughout the experiment until it became superconducting. At that point, contrary to what Meissner and Ochsenfeld had expected, the metal suddenly expelled the field. The two scientists could no more explain this behaviour than Onnes had been able to account for the sudden disappearance of superconductivity in a high magnetic field. But Meissner and Ochsenfeld did know that they had discovered a distinct and fundamental property of superconductivity now known as the Meissner effect . . . In 1960 Dr. Kunzler and a Bell Labs team concluded that the niobium-tin alloy would retain its superconductivity in magnetic fields exceeding 25,000 gauss. (A gauss is a unit of magnetic strength; the earth's magnetic field is about one-half gauss at the equator; a toy horseshoe magnet is a few hundred gauss). Half in jest, Kunzler proposed that his boss give him a bottle of Scotch for each 3,000 gauss increase about 18,000. His boss agreed. When tests were made several months later, the alloy proved theoretically able to retain its superconductivity in fields up to 200,000 gauss and Kunzler suddenly found a lot of whisky on his hands."

For the magnetically supported vehicles we have a problem of magnetic diffusion. The theoretical solution for this problem was done by Klauder, L. T., Jr., in 1969 (5). Present literature shows that there is

considerable increment in the studies and research work going on regarding magnetically supported vehicles. The flying carpet train concept was revived a few years ago by scientists at Brookhaven National Laboratories. Polgreen (9) has proposed a system with permanent magnets in both roadbed and vehicle.

C. Applications

One of the most recent applications for magnetically supported vehicles is discussed in this study. PRT (16) systems and the flying train (7) are the main vehicles being tested at the present time. The flying train is supposed to run at 300 miles an hour while riding 6 inches off the ground supported by intense magnetism as shown in Figure 1. In the PRT system the vehicles will run at 80 miles an hour in a city or populated region. Tube transportation is also one of the applications using the new proposed technique.

Some other concepts (7) for utilization of magnetic suspension are for sleeping on a cushion of magnetism which supports you as if you were on an atmospheric cushion. Even more futuristic offices, laboratories, etc., may be suspended magnetically (7) in space for better land use.

Superconductivity in magnetism has already resulted in the following important applications (7):

"Powerful superconducting magnets are at last a reality. Commercial superconducting electromagnets are now available with fields of 50,000 gauss. Some are no longer than a doughnut and their fields can be generated with an auto battery; a conventional magnet of equal strength weighs about 200 tons and uses 100,000 watts of power. At RCA, engineers have come up with a superconductivity magnet producing a continuous field of 150,000 gauss. At M.I.T. Dr. Bruce Montgomery of the Francis Bitter Magnet Laboratory expects to top this with a hybrid consisting of a conventional water-cooled electromagnet and a superconducting coil. He hopes that the combination will produce a field as high as 500,000 gauss.

In ore separation, a high-field magnet of this type is strong enough to remove impurities that are missed by conventional electromagnets.

In medicine, a superconducting magnet may make it possible to guide a metal-tipped catheter to a diseased organ without major surgery.

One of the most ambitious dreams of modern applied physics is to generate electricity with thermo nuclear fusion--the process which occurs in the hydrogen bomb and in the sun and the stars. To trigger thermo nuclear reactions, a heavy form of hydrogen called deuterium must be heated to 180,000,000 degrees F. But such a temperature is impossible to maintain in any material vessel. Scientists suggest, however, that the plasma, as these hot ionized gases are called, might be contained by a magnetic field whose lines of force act as a magnetic bottle to squeeze the plasma into a narrow space and hold it away from the container walls. Since conventional magnets would require incredible amounts of power to accomplish this feat, superconducting magnets promise a solution.

In the computer field, IBM scientists are developing a superconducting 'logic element' that can switch on and off in one-eighty-billionth of a second."

Engineers are working to apply the superconductivity principle to underground cables that will carry current over long distances without the costly losses of power

that occur in the present day cables. Another target of environmental criticism, the overhead power line, may disappear in the age of superconductivity.

D. Development of Technology

There are two important factors in developing magnetic suspension system: first, the geometric configuration of the current carrying coil with its position depending on the ratio of lift to drag force, and second the width of the roadbed.

1. Lift to Drag Force Ratio

Eddy currents are induced in the roadbed that results in a magnetic force which gives support to the train or any other vehicles. In any case, if we have superconducting coils, then this force can be produced with greater efficiency. When the moving coil supplies the eddy current loss in the bed, a drag force occurs.

The magnetic field penetrates the conducting slab and that is called diffusion. The higher the conductivity the faster the diffusion. If the diffusion is slower than the magnet speed, the magnetic field is compressed between the magnet and the slab and exerts a lifting force on the magnet. However, the field still penetrates the slab to some extent and force must be applied to drive the vehicle forward over the slab in that portion where the force has penetrated.

Thus there will be drag as well as lift. This event in the technique of magnetic suspension forces us to study the ratio of lift force to drag force so that a suspended vehicle can be propelled forward.

Robert H. Borcherts and John R. Reitz (6) developed a technique to calculate the ratio. Figure 3 is a sketch of an experimental system suggested by the author of this study showing a slight modification in the system that had been developed by Robert H. Borcherts and John R. Reitz. The only change is a spring and weight increasing technique. They performed the experiment as shown in Figure 3 without the spring and weight increment technique. They kept a constant height between the rotating wheel and the superconducting coil. They situated the magnet above the rotating conducting wheel as shown in the sketch. They wanted to know the effect of speed on the lift to drag force ratio. They used three different wheels. Dimensions of two of the wheels were 12 inches in diameter and 3 inches wide. The third wheel was 24 inches in diameter and 6 inches wide. With the 12 inch wheels one was solid aluminum and the other was a micarta. One wheel had a "hoop-like" aluminum rim 6 millimeters thick. The 24 inch diameter wheel was of solid aluminum.

Borcherts and Reitz (6) describe their experiment as follows:

"The superconducting magnets were made from 300 to 600 turns of 0.015 inch copper sheathed Nb-Ti wire purchased from Super Technology, Inc., Boston, Massachusetts. They

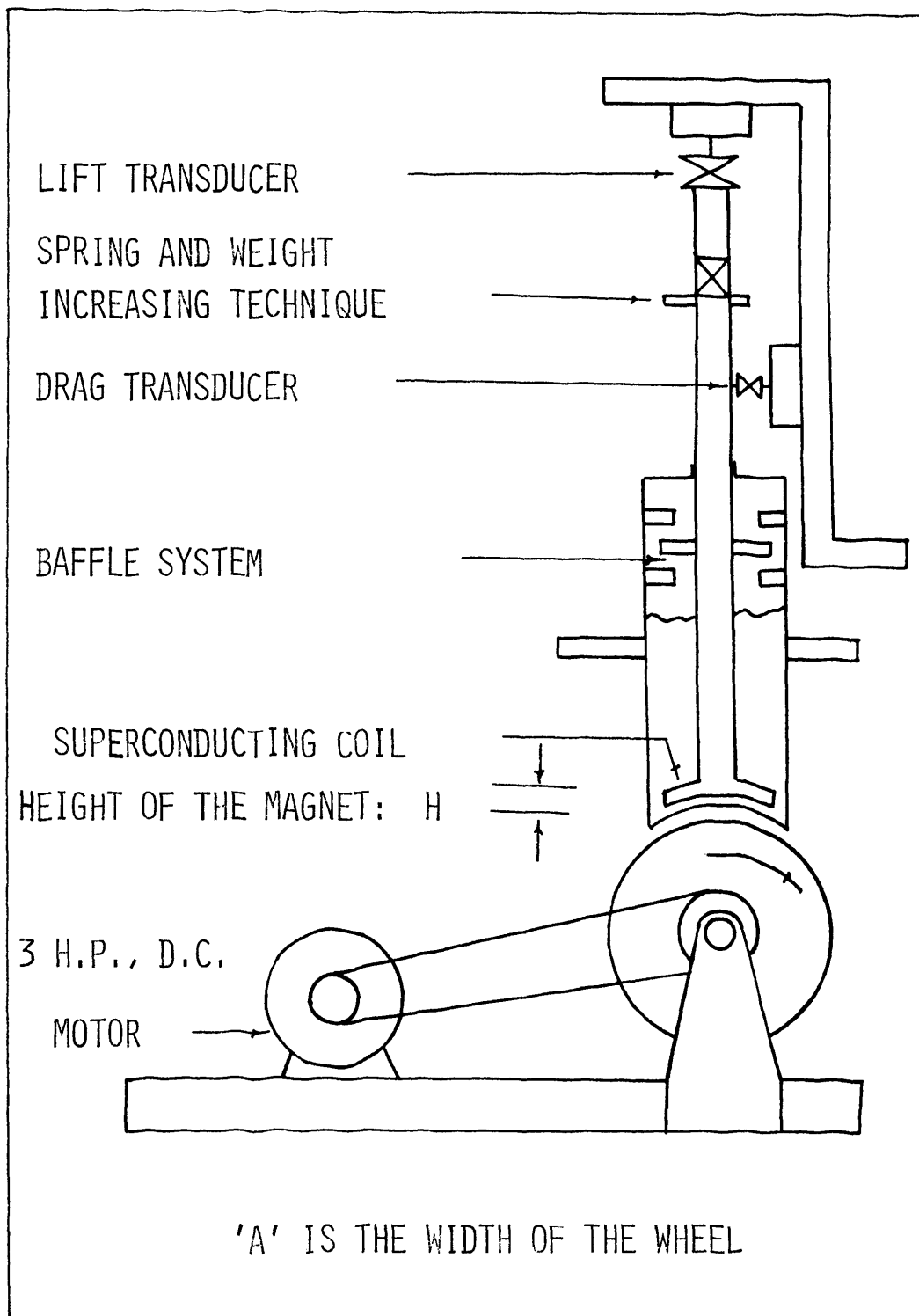

Figure 3-Modified sketch for experiment

were wound on aluminum coil forms shaped to the radius of the wheel. Rectangular (2 x 4 inches) as well as (2 x 2 inches and 3 x 3 inches) coil forms were used. Experiments were generally conducted with the magnet operating in the persistent mode carrying current as high as 70 amperes. Over the course of an experiment there was no observable decrease in the persistence. Lift and drag forces were measured by Daytronic LVDT transducers that were calibrated with known metric weights, and the speed of the rotating wheel was measured with a General Radio Strobotac."

The above procedure was carried out by Borcherts and Reitz (6) without spring action as shown in Figure 3. The author suggests a slight change in the conduct of the experiment regarding inclusion of the spring and weight increment technique as shown in Figure 3. The purpose of introducing this change is for better accuracy. As we know, a suspended vehicle will not be at a constant height at all times. To fulfill this aspect we must change our height often during the experiment. Hence if we include the spring and weight increment technique we can get more realistic results and we can have an accurate configuration and measurement of the current carrying coil. The weight and height both are related to each other in the magnetically suspended train. We must be accurate in our model study to get the most efficient system.

With this new change several readings of the lift and drag forces can be made. An increase in the weight will reduce the height and a decrease in weight will increase the height between the wheel and the superconducting magnet.

Thus we are able to change height quite often and we can then measure the true effect on lift forces and drag forces. One can perform the experiment for several situations. Thus the speed versus the lift force, the speed versus the drag force, and the speed versus their ratio can be plotted. To obtain a particular ratio at a particular speed one must change the geometric configuration of the coil. When we get the required ratio at a required speed then that will be the coil position in practice. This trial and error process is the simplest way to find out what the geometric configuration of the coil will be. Also, the proposed new change in the experiment will give accurate results.

Borcherts and Reitz (6) found that there is a difference in the theoretical values and experimental values for the above forces. The reason is only due to the concept of the infinite road width.

Borcherts and Reitz (6) stated their results as follows:

"A close analysis of the experimental geometry shows that if the coil is located in BTDC (before top dead centre) but still midway between the sides of the wheel; the measured lift to drag ratio would be 15 while the same distance ATDC would result in a ratio of 7.5 (a doubled drag force). This dependence is experimentally verified and primarily arises from the addition of a horizontal component of the large lift force to the drag force at the transducer. It is a fact that this effect is also responsible for the decreasing lift to drag ratio as the current is increased. One can determine the proper location of the coil for accurate measurements of the lift to drag ratio by noting the

change in the lift force as the coil is displaced fore and aft of the wheel centre line."

In fact by using a superconducting coil we can have a greater lift to drag ratio at a greater speed.

2. Width of the Roadbed

There is a relation between the height of the magnet H , Figure 2, and the width of the strip A . H/A ratio must be as low as possible to get a higher lift to drag force ratio. In 1969 Klauder (5) found the force amounts on a current carrying wire moving at a constant height H over a thick conducting plate. The "image" of the current carrying wire produces the lift force. Drag force decreases as velocity increases, $f = v^{-0.5}$.

Reynolds number is important when determining the type of fluid flow. Similarly the magnetic Reynolds number is the important factor in designing the width of the roadbed.

The following equation shows the magnetic Reynolds number (6):

$$R = \mu\sigma vH \quad (1)$$

where

$$\mu = \text{permiability of the roadbed, } \frac{\text{weber}}{\text{ampere-turn-meter}}$$

$$\sigma = \text{conductivity of the roadbed, } \frac{\text{ampere-turn-sec}}{\text{weber-meter}}$$

v = velocity, meter/sec

H = height of the magnet, meter.

The lift to drag ratio also depends on the magnetic Reynolds number. Let us define it:

$$M = \text{lift force/drag force.}$$

For high speed the ratio M is given by (6):

$$M = 2 \times (R/\pi)^{\frac{1}{2}} . \quad (2)$$

If we fix the ratio M we are able to determine the value of R . And R must be in the range of 10-200 for best performance. This range was determined by John R. Reitz (6) using cylindrical results which are the best fit to the flat roadbed case.

We know the fixed velocity for which we design. Thus we know R , velocity, permeability of the roadbed and the conductivity of the roadbed. By using equation (1) we are able to know the best height of the magnet above the roadbed. John R. Reitz (6) carried out the calculations for a moving monopole and moving dipole at various heights above the strip. Some of them are noted in Table I from which we are able to get the H/A ratio for a particular ratio M .

We know the exact height which will help in finding the roadbed width A . This is the simplest and most accurate way to find the width of the roadbed.

Table: I (6)

Relationship between the ratio of lift to drag force and
ratio of height of magnet and width of the roadbed

HEIGHT OF MAGNET, FEET WIDTH OF ROADBED	M* FOR THIN PLATE MODEL WITH INFINITE SHEET THEORY	M* FOR FINITE SHEET THEORY
	<u>WITH MONOPOLE</u>	
0.25	10.0	8.51
0.5	10.0	6.62
0.5	20.0	13.7
	<u>WITH DIPOLE</u>	
0.25	10.0	9.96
0.5	10.0	8.76
0.5	20.0	13.7

$M^* = \text{lift force/drag force}$

3. Track of the Vehicles

There is no necessity for a steel track as the train is suspended magnetically in the air. But it is essential to keep the vehicles in a straight line. There should not be movement to the right or left side. Figure 1 shows vertical magnets through the middle of the lower suspending coils. Those magnets produce a magnetic field to keep the train in the proper direction in the "flying train" system.

4. Linear Electric Motor

Any high speed vehicles need substantial amounts of drive power. Linear electric motors are a favorable drive mechanism, because they produce less environmental pollution along a transportation route than alternatives such as jet engines.

Linear induction motors with the electro magnetics (stator) on the vehicles and a conducting reaction rail (rotor) have been suggested for driving conventional wheeled trains as well as driving air-cushion or magnetically levitated vehicles (16).

The electro magnets (stator) on the vehicles require a third rail, a pantograph on a catenary wire or some other system to pick up power into the fast moving vehicles. Even though it would be easy to connect there is no power needed in the reaction rail (rotor) fixed to the track roadbed. Obviously the question arises as to whether the electro magnets (stator) should be on the roadbed. Thus

eliminating the requirement for a high speed system for transfer of electrical power to the vehicles. The vehicle could be simple and very light weight cars acting as their own reaction rail (rotor). Obviously, a far greater number of electro magnets (stator), which are more costly than the reaction rail (rotor), would have to be placed on the roadbed. However, if the density of the very small two passenger PRT (personal rapid transit) vehicles are great enough then the numbers of electro magnets on vehicles approach the number needed on a roadbed and the advantages of very light weight capsule reaction type vehicles become of prime importance. Also, there is then the possibility for incorporating very economically two separate systems of vehicle suspension. One would be an air cushion suspension in stations and linear town house developments with ambient atmospheric air pressures. The other would inject the vehicle into a vacuum tube where vehicles are suspended magnetically and linear electric motors could propel them at very high speeds to distant destinations.

5. Underground Power Distribution

Underground power supply will probably soon be economical. The electrical engineers conference record on underground distribution (12) states:

"Underground [power distribution] has been gaining prominence due to its lessened havoc to the visual and esthetic environment. Also, a maintenance plus, because of fewer breakdowns

as well as better safety features, has resulted where URD (underground residential distribution) has been utilized. The margin of additional expense in comparison with an overhead system, has been reduced from a ratio of 10:1 in 1950 to as low as 1:1 by 1970. URD is becoming a rule for almost any newly planned city . . . The conference record on Underground Distribution (sponsored by the Institute of Electrical and Electronic Engineers, Chicago, September 27-29, 1966) has been the guiding reference for compiling this cost-estimate on the planned URD for the new town of Pattonsburg, Missouri. . . . Wherever possible, to reduce overall costs the trench is shared by telephone companies and/or gas companies."

Table II shows the comparison of overhead and underground electric power transmission.

6. Conservation of Energy

The world's petroleum resources are limited and some means to conserve some of the oil for future generations is necessary. The magnetically suspended and propelled vehicle offers a means for mankind to practice petroleum fuel conservation.

D. P. Grimmer and K. Luszczynsky (3) discussed energy as follows:

"As shown in Table III energy used for transport propulsion accounts for about 29 percent of NEI (Net Energy Input) or total U. S. energy consumption. Fuel for automobiles, trucks, busses, and jet airplanes accounts for 81 percent of the (transport) propulsion energy. Further breakdown of the NEI data in the industrial sector reveals that energy used by the transportation sector is in fact considerably higher than 29 percent. When energy consumption for secondary - transport - related activities such as fuel refining and

Table: II (12)

Comparison of underground to overhead power transmission

ESTIMATED AVERAGE COST RATIO - UNDERGROUND TO OVERHEAD

	<u>Prior to 1960</u>	<u>End of 1963</u>	<u>End of 1965</u>	<u>Estimated 1970</u>
High	10/1	5/1	3/1	2.5/1
Low	1.3/1	1.1/1	1.1/1	0.85/1
Average	4/1	2.4/1	1.7/1	1.4/1

ESTIMATED AVERAGE COST PER FRONT FOOT

	<u>Prior to 1960</u>	<u>End of 1963</u>	<u>End of 1965</u>	<u>Estimated 1970</u>
High	13.30	9.10	6.90	6.70
Low	1.82	1.68	1.43	1.25
Average	6.86	4.95	3.42	2.89

Table: III (3)

U. S. Energy budget in QBTUs (Quadrillion BTUs) for 1968

Sector	Gross Energy Input (GEI)	Electricity Purchased (or sold)	Net Energy Input (NEI)	% of NEI
Household and commercial	13.6	2.5	16.1	30.4%
Industry	19.4	2.0	21.4	40.5%
Transportation (propulsion)	15.2	0.0**	15.2	28.7%
Electricity, generation, utilities	<u>14.0</u>	<u>[4.5]+</u>	<u>++</u>	<u> </u>
Totals †	62.4	...	52.9	100%

*Industry generated about 0.34 QBTUs of electricity (Federal Power Commission, 1969 Annual Report)

**Propulsion accounted only for 0.018 QBTU or 0.4% of electricity sold

+This is equal to the total electricity purchased. The energy lost in electricity generation by utilities was 9.5 QBTUs

++Electricity sold (4.5 QBTUs) is added into first two entries above, and thus is not included here; the remaining 9.5 QBTUs of electricity were those lost by utilities, and thus are not included either. The NEI thus is energy available for end use by households, commercial establishments, industry, and transportation

†Includes miscellaneous and unaccounted for uses (about 0.3 QBTU). Entries may not add to total because of rounding off numbers.

SOURCE: U. S. Bureau of Mines, Minerals Yearbook, p. 24, 1968.

manufacture of transportation equipment is included, energy expended for transportation rises to a total of 38 percent of the NEI as is shown in Table IV.

In addition to the principal uses shown explicitly in Table IV, there are many small miscellaneous items which are difficult to evaluate because there is a lack of good data in this area . . .

The present transport propulsion is almost entirely based on petroleum which provides 95 percent of the energy; electric power supplies only about 0.1 percent. However a good deal of electricity is used in the secondary-transport-related activities. Using U. S. Bureau of Mines statistics, we estimate that utility electricity use in this area accounts for about 0.9 percent of the U. S. NEI or about 11 percent of electricity purchased in 1968 a factor which does not show up explicitly in Tables III or IV."

This indicates that present transportation will be more costly in the future. The almost frictionless magnetically supported vehicles will be the most efficient for conservation of energy as they save fuel.

Table: IV (3)

Energy for transportation in QBTUs (Quadrillion BTUs)

SECTOR	USE	(QBTU)	TOTAL QBTU	% OF NET ENERGY INPUT*
Primary transport propulsion	Automobile	7.60		
	Truck and bus	3.06		
	Jet	1.63		
	Railroads	0.72		
	Marine	0.55		
	All other prop.	1.59	15.15	29%
Secondary transport (related activities)	Fuel refining asphalt and road oil, energy	2.42		
	Primary metals used in trans- port manu- facture	1.02		
	Manufacturing	0.53		
	All other secondary	1.05	5.02	<u>9%</u>
	Total			38%

*See Table IV caption for definition of Net Energy Input

III. DISCUSSION

A. The Proposed System

The study proposes an efficient transportation system which would solve many of the present transportation problems. In this new transportation system the vehicle is suspended on a cushion of magnetism in a magnetic field. The following are the vehicles for the proposed system.

1. Flying Train

Figure 1 shows the concept of the train. The name itself suggests that it has no steel track. The supplied power in the vehicle induces the eddy currents in the conducting roadbed resulting in the magnetic field. The magnetic field suspends the train and due to linear motor action the train accelerates to 300 miles an hour. The vehicle magnets produce the magnetic field which keeps the train in the proper direction as shown in Figure 1. Lift to drag force ratio technique helps in finding the configuration of the current carrying coil. The only problem is how to transfer the power to the high speed vehicle. The problem is solved by the PRT (personal rapid transit) developed by the Rohr Corporation (16).

2. PRT System

The concept would be as shown in Figure 2. The small vehicle having 2 to 6 passengers capacity, is supplied with a permanent magnet in the bottom portion of the vehicle. Underground power distribution supplies the power in the roadbed to produce magnetic field through electromagnets. Electromagnets produce a magnetic field which suspends the vehicle and keeps it off the track. The roadbed acts as a stator and the light weight vehicle acts as a rotor of the linear induction motor (LIM). The speed of the vehicle would be obtained up to 80 miles an hour. This is efficient transportation systems with the great capacity and economic operation as discussed in the further study.

B. Environmental and Economic Aspects

There is an intensified concern with the physical environment and it is clear that we need to know more about the total environment.

1. Noise Pollution Control

One of the chief complaints about transportation noise is its disturbance of sleep and relaxation. The major

offender is the airplane, owing to its loudness and unexpectedness. Sonic booms in the future are expected to aggravate the problem. Sleep is also disturbed if one's residence is near a highway or a roadway carrying heavy traffic. Disturbance of sleep is of primary importance because proper rest is necessary for normal psychological and physiological functioning of the human body. There is traffic noise in any downtown during both day and night. For people living downtown or near a highway or airport it is necessary to keep windows closed and noise insulate their homes. When people travel, however, everyone wants to ride in an airplane and save large amounts of time due to the high speed of the plane. Those people who take their cars on long trips likewise save time by increasing the speed of their cars as high as possible. Both of these modes of travel generate a great amount of noise.

Magnetically supported vehicles can solve most of the noise pollution problem as they are frictionless. They do not have any rotating wheels or parts which make contact with the ground. They do, however, make noise when they are operated at high speed in the open air. Consequently, there are many proposals to place the vehicles in tubes or tunnels for operation in a partial vacuum. If operated in a tube, these vehicles do solve almost all of our traffic noise pollution problems as well as provide high speed

transportation. A magnetically suspended train can run at 300 miles an hour without making much noise. For future cities or cities like Chicago, New York, Washington D.C., Detroit, etc., the noise pollution problem can also be solved by the PRT systems or personal transit vehicles. A PRT system will allow the traveler to board at a station located off the main track or guideway, for example within a department store or factory, and after having indicated his final destination to a computerized routing system the vehicle proceeds continuously and directly from origin point to destination point at speeds of 80 miles an hour. The new technology enables us to solve most of the traffic noise pollution problem with magnetically supported vehicles.

2. Air Pollution Control

Today's great problem is air pollution in the metropolitan areas of big cities. The Federal government spends much money pursuing air pollution abatement. Air pollution is due to factories, automobiles, sewage treatment plants, electrical power stations, etc. Statistical source study reports indicate that 60 to 70 percent of air pollution is due to automobiles. Hydrocarbons, carbon monoxide and nitrogen oxide are the main gases coming from the exhausts of automobiles which pollute the air. Several lung diseases are common in major cities and their cause has been

traced to air pollution. Polluted air can reduce the physical strength of human beings not because it hasn't sufficient oxygen, but because it contains the gases which have bad effects on the internal physical system.

Table V shows the federal standards for hydrocarbons and carbon monoxide emission from cars and light trucks. New techniques can control the polluting gases from cars. But the addition of such new controls increases the cost of the cars. This, besides the rapidly increasing cost of fuel, again indicates that automobile transportation will be much costlier in the very near future.

Air pollution is due to the emission of the gases from the automobiles and small rubber particles in the atmosphere from the tires. Magnetically supported vehicles do not use tires or fuel. They do, however, use fuel at the power plant. These vehicles do not emit any gas which can pollute the air. No doubt the pollution will increase at the power plant but it will be far from the city. Thus by using magnetically supported vehicles we can solve almost all air pollution problems within the city area caused by the present transportation system.

3. Land Use Efficiency

U. S. Department of Commerce BPR (10, p. 19) states that traffic and transportation facilities and parking

Table: V*

Standards for allowable emission of gases

Exhaust	Emission From		Allowable Emission	
	Typical	Uncontrolled Car	Model Year 1968	Model Year 1970
Hydrocarbons	900 PPM		275 PPM ^a (3.2 grams per ve- hicle mile)	180 PPM ^a (2.2 grams per ve- hicle mi.)
Carbon Monoxide	3.5%		1.5% ^a (33 grams per vehicle mi.)	1.0% ^a (23 grams per ve- hicle mi.)
<u>CRANKCASE BLOW BY:</u>				
Hydrocarbons	20-25% of total hydrocarbons emitted		0.0	0.0
<u>EVAPORATION FROM FUEL TANK AND CARBURATOR:</u>				
Hydrocarbons	1.5% of total hydrocarbons emitted		No standard	6 grams per test (equiva- lent to 90% con- trol)

*P.T.O.

*Source of the Table: Control of Air Pollution from New Motor Vehicle Engines, Standards for Exhaust Emission, Fuel Evaporative Emissions, and Smoke Emissions, Applicable to 1970 and Later Vehicles and Engines. Fed. Regis.

"a" Standards shown for 1968 are for engines of more than 140 cubic inches displacement. Allowable emission increase with decreasing engine size to a maximum of 410 ppm hydrocarbons and 2.3% carbon monoxide for less than 50 cubic inches displacement. The standards for 1970 do not change with engine size because they are on a mass basis in grams per vehicle mile, as opposed to the 1968 standards which are on a volume basis parts per million and percent. Emission values in the parenthesis in column for 1968 and 1970 are the volume for mass equivalent of the standards shown. Emissions are measured with nondispersive infrared analyzers.

space requires 36 percent of the land in cities of 100,000 to 250,000 population, and for cities of 500,000 to 1,000,000 population requires 46 percent of the land in the business district of the city. Population growth indicates that there will be more need of the land for other uses. In addition to the land use problem the problems for metropolitan areas and on highways are traffic control and traffic accidents. It will be difficult to get more land in the future because the buildings will be in the same places where streets and freeways may be required. In this situation, we must find other systems of transportation which can solve the problems regarding needs of the land for other than transportation in the future. It is very difficult to reform the cities as it is extremely costly. It would be better to find another traffic system which can save the land without reforming the old cities. One technique under development that does not require massive demolition and very difficult construction is computer controlled magnetically supported PRT vehicles. The PRT system can solve the parking and accident problem and at the same time attain higher speeds. Computer control technology will handle the traffic which will be the safest for metropolitan society. This system solves the complicated problem regarding the signal lights and other problems of traffic control. We can do much better on the land that we have if we install a PRT system.

There are many possibilities to establish scenic areas along the way, which can help provide aesthetic relief. We can have more extra land for other more beneficial uses if we adopt the magnetically supported vehicles.

J. S. Robinson and R. E. Skorpil (11, p. 19) gives land value increases - a potential source of benefit in their article:

"Transit studies have shown that one impact of major importance is the transit-induced development of real estate occurring in areas adjacent to transit stations. As experienced by Toronto and other cities, demand for land near rapid transit stops is great, and results in sharp increases in land values. In the case of Toronto, land values around the stations have increased 300 to 400 percent (or more) within five years of the construction of the transit system. In the past, quick-acting speculators and developers have capitalized on this appreciation of land value, realizing enormous profits through prudent land purchase and resale. The capture strategies presented here, related to increases in land value, represent possible ways for the community to receive greater benefit from these gains."

The capture strategies tax progressively the land value increases to help the government recover some of the enormous public subsidies expended in constructing mass transit systems.

4. Fare Charge Per Passenger and Capacity

Aerospace Corporation made a study (14) comparing the cost of a computer-controlled wheel mounted PRT system with the proposed 189 mile railroad transit system for Los Angeles:

"The Aerospace projection of the cost of PRT systems is about \$2 million per mile of one-way line, excluding vehicles. This includes guideway, stations, cleaning facilities, central headquarters, and electrification. The study gave an interesting comparison in the cost of transit systems. For the same cost as the proposed 189 mile rail mass transit system for Los Angeles, a 468 mile PRT network could be built, with 455 stations and 74,000 vehicles. The 189 mile rail network could have only 67 stations.

It was found that in an area of 6,000 people per square mile, the PRT fare would be 4-7 cents per mile, whereas an area of 4,000 people per square mile would require fares of 5-9 cents per occupied car mile."

This shows that we can have PRT transportation systems having a fare of 5-9 cents instead of 35-50 cents per person on present mass transit systems.

Aerospace Corporation gives the following information regarding capacity for PRT vehicles:

"Assuming a six passenger vehicle, the line capacity would be 86,400 people per hour. Undoubtedly, the vehicles will not all be full, but even if an average occupancy of 1.2 persons per vehicle is assumed, a capacity of 17,300 people per hour is realized. A problem arises at intersections when line density approaches 100 percent, but a recent intersection negotiation concept has reduced this considerably. With one type of intersection, with the line operating at a density of 80 percent and 30 percent of the cars wanting to turn, it was found that 20 percent of the cars would "miss" the turn. Missing the turn simply means the control computer decides the turn cannot be made and sends the vehicle around the nearest loop. It is not a departure from safe operation. With the new concept, the miss rate was reduced to zero for 80 percent line density, 1 percent for 90 percent density, and 5 percent for 95 percent density, all assuming a 30 percent turn rate. The other problem is

the question of whether in practice vehicles can operate at one-sixth second time headways. Even if the expectations of aerospace cannot be met, it is evident that PRT systems can have a very high capacity."

5. Economics and Cost Trends

Now-a-days all auto industries try to add new techniques for air pollution control which increases the cost of the automobiles. Also, we are going to soon face the shortages of fuel in the future as it is predicted. Due to these reasons the common man will find it more and more difficult to keep an automobile. People with average incomes will ride in mass transit or the more preferred PRT system.

D. P. Grimmer (3) shows in his article that 8,000 BTUs per passenger mile (130,000 BTUs per gallon) is required for propulsion of automobiles while a fast train requires only 980 BTUs per passenger mile. This shows that trains use 1/8 (one-eighth) of the power that is used in automobiles with rubber tires. This would indicate that PRT uses much less power than that used in automobiles.

Installation charge for PRT system is \$2 million per mile as stated before. This excludes the cost of vehicle but includes guideways, stations, cleaning facilities, headquarters, and electrification. R. E. Skorpil and J. S. Robinson (11) state the cost of road construction is

about \$7 to 10.5 million per mile, excluding maintenance, stations, and signal lights. The cost of vehicles for the PRT system will be lower than that of the present automobile. Aluminum can be used to decrease the weight of capsule which reduces its cost. As the system operates automatically there is no necessity of an operator. Hence PRT system can solve wage cost problems. The PRT system can be used in the city areas as well as in between cities. This concludes that the PRT system will be economic as compared to the present transportation system.

6. Comparison With Present System

Reduction of the friction between vehicles and the ground can be achieved by the use of wheels. Archaeologists trace the invention of the wheel to Central Asia some 3000 years ago. Refinements of wheel technology over that long span of time has improved and diversified the innumerable uses of the wheel that we have today. However, we are not able to make a completely frictionless system while using wheels. This new change in technique to a magnetic suspension gives us a frictionless transportation system. We make our automobile move comfortably over uneven surfaces by using flexible tires, springs, and shock absorbers. Magnetically supported vehicles should provide a most comfortable ride as they will run on a cushion of magnetism. A computer will automatically control the routing

of these vehicles rapidly, safely, and directly from origin point to destination point. A passenger can watch a TV set while he travels. The change in technology to be a new system of magnetically suspended vehicles as contrasted with the present system may be acceptable to society as people desire a change that improves their comfort, safety, and saves them time.

7. Government Attitude

Now-a-days local as well as state and federal governments are looking for high speed transportation which can protect all the environmental aspects as well as simplify the complications in the present transportation system. As was discussed before, the magnetically supported vehicles satisfy almost all our defined needs. Government will be assisted by this new system. An improved governmental reputation can result if the new change is beneficial to the public.

The government should be in favor of a new technology such as PRT that promises to attract a far greater percentage of traffic use than MT (mass transit) systems now in use or being built. In most cases MT carries no more than ten to fifteen percent of the travel in a metropolitan area. It is predicted that PRT will carry fifty percent or more of the travel.

IV. CONCLUSION

A. Summary

The flying train is costlier than the PRT system but it is introduced for further investigations.

The magnetically supported PRT system has the following main features:

1. Automatic operation.
2. Direct transport without changes or stops between departure and arrival.
3. Electric propulsion, therefore, no noise or exhaust fumes which minimize the noise and air pollution problems.
4. Operation can be carried out without the congestion, dangers, and frustrations of driving.
5. In the PRT system the weight of the car should be light so that the car could be operated as a rotor of the linear induction motor.
6. Capacity of the PRT system would typically be 86,400 people per hour. In an area of 6,000 people per square mile, the PRT fare would be 4-7 cents per passenger mile, whereas area of 4,000 people per square mile would require fares of 5-9 cents per occupied car.
7. The cost of guideway, stations, cleaning facilities, central headquarters, and electrification is about 2 million per mile.

8. With the above cost the PRT system will be economic in the city area as well as in between cities as compared to the present transportation.

B. Technical Recommendations

1. New techniques are described in the study for realistic and good results in getting the lift to drag force ratio.
2. LIM (Linear Induction Motor) is the best to propel the capsule for the PRT system.

BIBLIOGRAPHY

1. American Railway Engineering Association, Opening Session Address, Bulletin, Vol. 73, June-July 1972, p. 5.
2. Coffey, H. T., Chilton, F., and Barbee, T. W., Jr., (1969). Suspension and Guidance of Vehicles by Super Conducting Magnets. Journal of Applied Physics, 40, p. 216.
3. Grimmer, D. P., and Luszczynski, K., Lost Power Environment, Vol. 14, No. 3, April 1972, p. 14-16.
4. Guderjahn, C. A., Fink, H. J., Boom, R. W., and Mackenzie, K. E. (1965). Magnetic Suspension and Guidance for High Speed Rockets. Journal of Applied Physics, 40, p. 2133.
5. Klauder, L. T., Jr. (1969). A Magnetic Diffusion Problem. American Journal of Physics, Vol. 37, p. 323.
6. Borcherts, Robert H., and Reitz, John R., High Speed Transportation Via Magnetically Supported Vehicles. (1971). Transportation Research, Vol. 5, No. 3, p. 197-200.
7. Edson, Lee, Super Conductivity. (1970). Nature/Science Annual, Time-Life Books, New York, p. 143-150.
8. Railroad Review and Outlook. (1970). Wage Rates and Prices. January, p. 31.
9. Polgreen, G. R., Guided Land Transport. Proc. Inst. Mech. Engrs., Vol. 181, p. 145.

10. Parking Guide for Cities (1956). U. S. Department of Commerce, BPR (Bureau of Public Roads), Washington, p. 19.
11. Robinson, J. S., and Skorpil, R. E., Optional Strategies for Increasing the Return on Transit Investment. (1970). Westinghouse Engineer, January, Vol. 30, No. 1, p. 8-9.
12. Conference-Record Supplement, Special Technical Conference on Underground Distribution, sponsored by the IEEE Power Group, p. 25.
13. Rockefeller, Nelson A., Grow With the Empire State. (1970). Your Future in Transportation, State of New York, Civil Engineers, Department of Transportation, January, p. 1.
14. Aerospace Corporation, High Capacity Personal Rapid Transit, BiWeekly, Vol. 1, No. 6, October 28, 1971, p. 49.
15. Marketing Information, A Personal Rapid Transportation Demonstration by TTI (Transportation Technology, Inc.). A subsidiary of Otis Elevator Company. Company advertising.
16. TRANPO 72 Report, Electromagnetic Levitation. (1972). Traffic Engineering + Control, July, Vol. 14, No. 3, p. 135-141.

VITA

Pravinchandra Shukla was born on August 2, 1946 in Mahisa City, Gujarat State in India. He received his primary and secondary school education in Mahisa City. He received his B.S. degree in Electrical Engineering in December 1969 from Sardar Patel University, India with first class. He was awarded a tuition fee scholarship during his B.S. study.

Mr. Shukla received his diploma for M.S. in Electrical Engineering in August, 1971, from the University of Missouri-Columbia. He has been enrolled in the Graduate School of the University of Missouri - Rolla since September 1971 for his second M.S. degree in Environmental and Planning Engineering. He was granted a Graduate Research Assistantship during the Fall of 1971 and a Graduate Assistantship from February 1972 to October 1972.

He is interested in metaphysics.